

PANDUIT PART NO.	MAX BUNDLE DIA.	PACKAGE QTY	LENGTH L ±.3 [7]
MLTFC2S-CP316	2" [51]	100	7.9" [201]
MLTFC4S-CP316	4" [102]	100	14.3" [362]
MLTFC6S-CP316	6" [152]	100	20.5" [521]
MLTFC8S-CP316	8" [203]	100	26.8" [679]

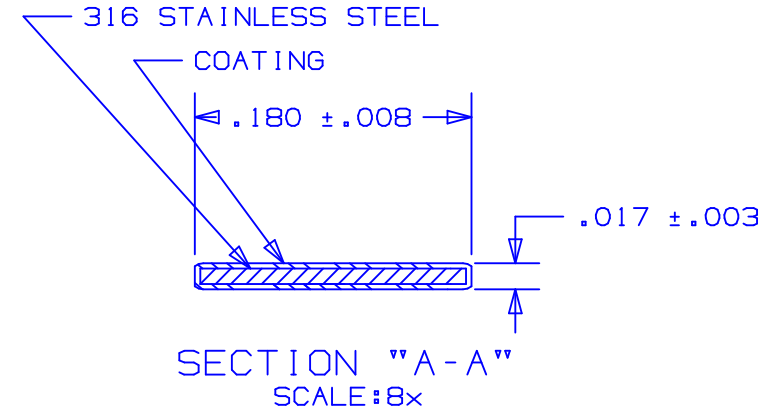
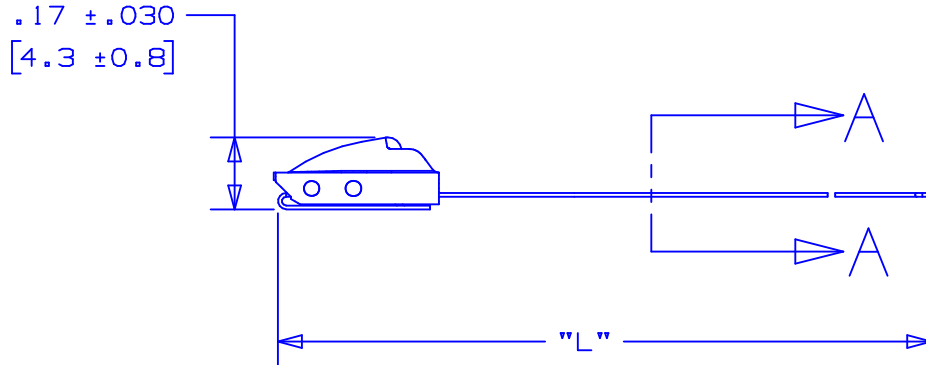
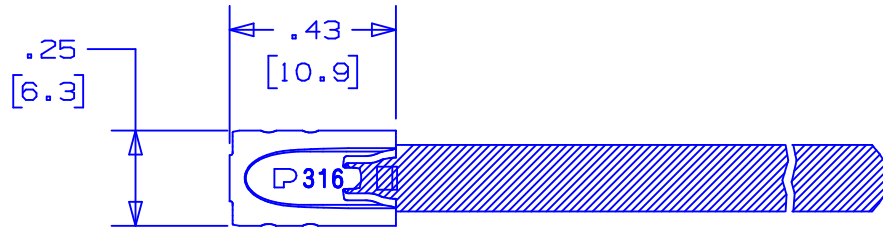

NOTES:

- 1.) APPLICATION TOOLS - GS4MT,PPTMT,ST2MT,ST3MT,HTMT
- 2.) MINIMUM LOOP TENSILE STRENGTH - 100 LBS. (445 NEWTONS) WHEN TESTED ON A 1.5" MANDREL.
- 3.) [] DENOTES DIMENSION IN MILLIMETERS
- 4.) TOLERANCES:
 - .XXX = ±.010 [.25]
 - .XX = ±.02 [.5]
 - .X = ±.03 [.8]
 - ANGLES = ±2°
- 5.) MATERIAL: 316 STAINLESS STEEL
- 6.) COATING - POLYESTER
COATING THICKNESS: .002 MIN./ .005 MAX. PER SIDE

S41214_00

PANDUIT

CORP.

TINLEY PARK, ILLINOIS

METAL LOCKING TIE - COATED
STANDARD SERIES-316 STAINLESS STEEL
(CUSTOMER DRAWING)

00	8/05	JAMB	EJD	RELEASED	SS00021
REV	DATE	BY	CHK	DESCRIPTION	ECN #

DRAWN BY JAMB	CHK'D EJD	SCALE 2x	DRAWING NO. S41214
------------------	--------------	-------------	-----------------------